

MULTIPROCESSOR

CK składa się z uniwersalnej bazy, do której zaczepiane są różne zestawy szczęk rozbiórkowych. Dzięki innowacyjnemu półautomatycznemu systemowi, nie musisz ręcznie usuwać sworzni konstrukcyjnych i możesz wymienić zestaw w 5 minut. Dostępny ze szczękami Primary, Pulverizer, Combi, Swiss, Shear i Tank.

MULTIPROCESSOR

The CK consists of a universal body to which different demolition jaws kits are hooked. Thanks to an innovative release semi-automatic system you do not have to remove structural pins manually and can change the kit in 5 minutes. Available with Primary, Pulverizer, Combi, Swiss, Shear and Tank jaws.

MULTIPROCESSEUR

Le CK est constitué d'un bâti universel auquel sont accrochés différents kits de mâchoires de démolition. Grâce à un système semi-automatique de déverrouillage innovant, vous n'avez pas à retirer les axes de verrouillage, ce qui permet de changer la mâchoire en 5 minutes. Différentes mâchoires sont disponibles : Pince Béton, Broyeur, Combi, Suisse, Cisaille à Ferraille et Grugeuse.

MODEL

t min

t optimal

t max

CK07

7

8 / 12

13

CK11

10

11 / 15

16

CK14

14

15 / 20

21

CK21

19

20 / 26

27

CK28

26

28 / 34

35

CK36

34

36 / 46

50

Zakres wagowy koparki
Excavator weight range
Couplage poids équipement / pelle

MODEL	Baza	l/min	bar	l/min	bar
	kg				
CK07	490	5 / 15	120	70 / 90	230 / 350
CK11	600	5 / 15	120	90 / 140	280 / 350
CK14	990	10 / 20	120	110 / 160	350
CK21	1230	15 / 25	120	170 / 210	350
CK28	1630	40 / 50	120	200 / 250	350
CK36	2190	50 / 60	120	300 / 400	350

MULTIPROCESSOR

CK



6
MODELI

6
RODZAJÓW
SZCZEK

SPEED
VALVE

- › Wymienny system płyt z zębami (od CK11)
- › Wymienne i odwracalne ostrza tnące
- › Zawór (speed valve) o dużej prędkości przepływu zapewnia krótszy czas cyklu (od CK14)
- › Układ hydrauliczny jest łatwo dostępny przez przykręcane włazy



- › Replaceable bolt on tooth and/or tooth plate system (from CK11)
- › Interchangeable & reversible cutting blades
- › A high flow speed valve achieves the faster cycle time (from CK14)
- › Hydraulics are easily accessible through bolted hatches

- › Plaques de dents boulonnées et/ou dents remplaçables (à partir du CK11)
- › Couteaux réversibles et interchangeables
- › Speed valve de série pour réduire le temps de cycle (à partir du CK14)
- › L'hydraulique est facilement accessible par des trappes d'accès boulonnées



Inne modele szczęk dostępne na zamówienie
Other models of Jaws available on request
Autres types de mâchoires sont disponibles sur demande

D - Crusher

MODEL	Typ szczęki	Łącznie	Szczeka	A	B	C	D	E		F3	
		kg	kg	mm	mm	mm	mm	mm			
CK07	D	740	250	1605	530	500	50	190	150	32 / 45	20
CK11	D	1105	505	1725	610	580	60	292	150	40 / 53	25
CK14	D	1630	640	2035	710	700	143	292	200	65	30
CK21	D	2100	870	2080	780	760	143	292	200	80	35
CK28	D	2745	1115	2400	865	810	143	312	200	105	40
CK36	D	3715	1525	2550	955	910	143	332	200	120	50

P - Pulverizer

MODEL	Typ szczęki	Łącznie	Szczeka	A	B	C	D	E		F3	
		kg	kg	mm	mm	mm	mm	mm			
CK07	P	770	280	1630	535	525	200	290	85	32 / 45	20
CK11	P	1085	485	1750	615	730	225	350	150	40 / 53	25
CK14	P	1635	645	2075	730	730	260	404	150	65	30
CK21	P	2080	850	2115	785	780	260	404	200	80	35
CK28	P	2790	1160	2454	870	880	290	454	200	105	40
CK36	P	3830	1640	2635	980	930	315	490	200	120	50

R - Combi

MODEL	Typ szczęki	Łącznie	Szczeka	A	B/B1	C/C1	D	E		F3		IPE I	HEA II
		kg	kg	mm	mm	mm	mm	mm					
CK07	R	790	300	1600	530 / 265	480 / 280	60	230	280	32 / 45	30	80	0
CK11	R	1135	535	1725	610 / 320	580 / 320	112	272	320	40 / 53	35	120	100
CK14	R	1680	690	2035	720 / 338	700 / 340	143	302	340	65	40	140	120
CK21	R	2150	920	2080	780 / 358	760 / 340	143	302	340	80	45	220	140
CK28	R	2855	1225	2400	870 / 440	810 / 430	143	388	430	105	50	240	180
CK36	R	3890	1700	2550	930 / 470	910 / 430	160	415	430	120	60	330	220

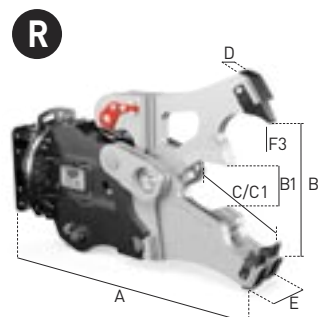
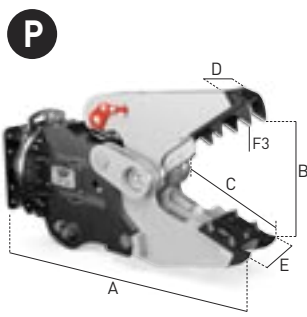
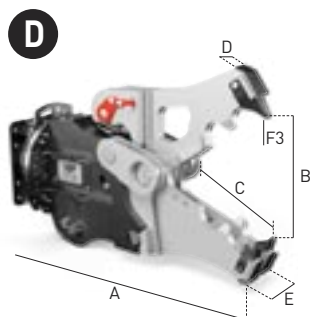

S - Shear

MODEL	Typ szczęki	Łącznie	Szczęka	A	B	C	D	E	F3	●	—	IPE I	HEA I
		kg	kg	mm	mm	mm	mm	mm	t	mm	mm	mm	mm
CK07	S	770	280	1510	235	335	90	258	45 / 65	30	3	80	-
CK11	S	1040	440	1605	290	340	90	258	60 / 75	35	6	120	100
CK14	S	1610	620	1930	346	493	105	309	85	40	8	140	120
CK21	S	2035	805	1900	360	493	105	300	110	45	10	220	140
CK28	S	2705	1075	2230	425	600	120	380	140	50	12	240	180
CK36	S	3710	1520	2395	485	650	120	415	165	60	15	330	220

CH - Swiss

MODEL	Typ szczęki	Łącznie	Szczęka	A	B/B1	C/C1	D/D1	E	F3	●
		kg	kg	mm	mm	mm	mm	mm	t	mm
CK07	CH	800	310	1585	350 / 0	430 / 0	195 / 0	300	40 / 60	20
CK11	CH	1075	475	1690	425 / 0	510 / 0	205 / 0	330	52 / 65	25
CK14	CH	1710	720	2015	525 / 420	630 / 410	143 / 222	402	70	30
CK21	CH	2180	950	2085	595 / 460	677 / 470	145 / 262	442	85	35
CK28	CH	2935	1305	2445	745 / 690	795 / 593	145 / 292	482	110	40
CK36	CH	3965	1775	2600	830 / 720	870 / 610	145 / 320	522	120	50

T - Tank

MODEL	Typ szczęki	Łącznie	Szczęka	A	B	C	D	E	F3	—
		kg	kg	mm	mm	mm	mm	mm	t	mm
CK11	T	1200	600	1750	250	300	58	220	72	10
CK14	T	1870	880	2055	295	363	78	280	96	12
CK21	T	2370	1140	2055	325	363	78	300	121	15
CK28	T	3050	1420	2350	375	394	78	320	158	20
CK36	T	4290	2100	2545	460	470	98	360	171	25

